

MS799

Large NEMA 4X Housing with Hinged Cover

FEATURES:

- Molded fiberglass polyester has outstanding chemical and temperature resistance qualities and exhibits excellent weatherability and physical properties
- Accommodates Flow Computer(s) and Accessories (printers, converters, etc.)
- Seamless foam-in-place gasket assures watertight and dust tight seal
- Polyester mounting brackets and stainless steel attachment screws are provided with each enclosure
- Hinge pin and bail are corrosion-resistant Type 316 stainless steel
- Padlock provisions included in each latch

Description

Designed for use with the SUPERtrol series of products for both indoor and outdoor settings. The enclosure is large enough to fit up to three SUPERtrol series units and also house accessories inside. It is used in highly corrosive environments typically found in oil refineries, chemical processing plants, waste water treatment, marine installations, pulp and paper processing, and electroplating plants. The efficient design and simple construction create a low-cost, durable, and aesthetic enclosure.

Industry Standards

UL 508A, File No. E61997: Type 4, 4X, 12, and 13
NEMA/EEMAC Type 4, 4X, 12, and 13
Enclosure flammability rating per UL 508A
Window flammability rating per UL 508A
CSA File No. 42186: Type 4, 4X, 12, and 13
IEC 60529, IP66

Ordering Information:

Part Number:

- MS799NEMAST4X0 - enclosure with no cutouts
- MS799NEMAST4X1 - enclosure with 1 cutout
- MS799NEMAST4X2 - enclosure with 2 cutouts

Options:

- A - Assembled at KEP
- QR - Quick Release Latches
- SP - Sub-Panel
- DR1 - Single DIN Rail Installed for accessory mounting
- DR2 - Double DIN Rail Installed for accessory mounting
- SW - Power Disconnect Switch
- AE - Auxiliary Enclosure
- TB - Terminal Block in Auxiliary Enclosure
- PW - Internal Pre-wired by KEP
- 3H2 - Three 0.5" Conduit Entries
- 6H2 - Six 0.5" Conduit Entries

Consult factory for custom conduit hole and hub fitting options.

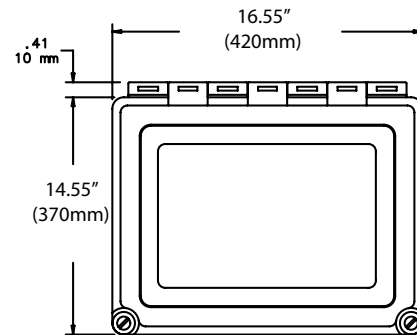

TOP VIEW

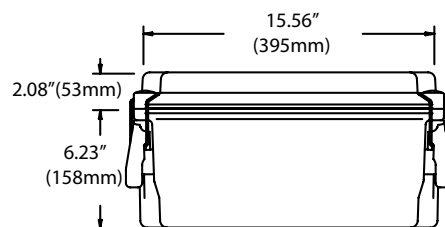

SIDE VIEW

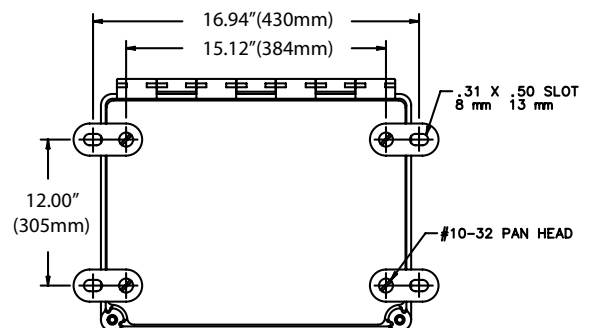

BOTTOM VIEW



KESSLER-ELLIS PRODUCTS 10 Industrial Way East, Eatontown, NJ 07724
800-631-2165 • 732-935-1320 • Fax 732-935-9344 • <http://www.kep.com>